

CC BRACKET 1" BATTENS

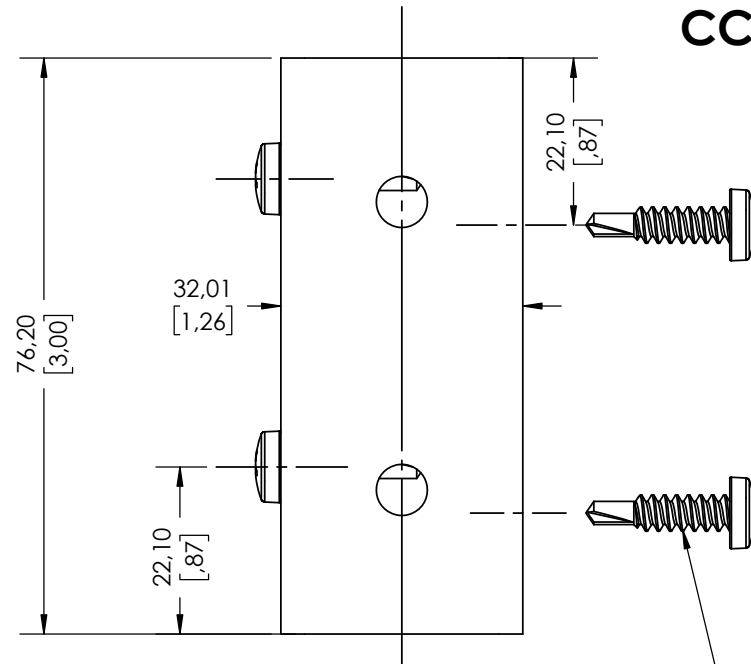

(4x) Painted 10-16 x 0.75"
self-drilling screws
per bracket (included)

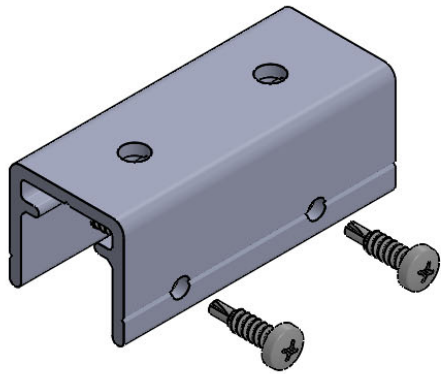
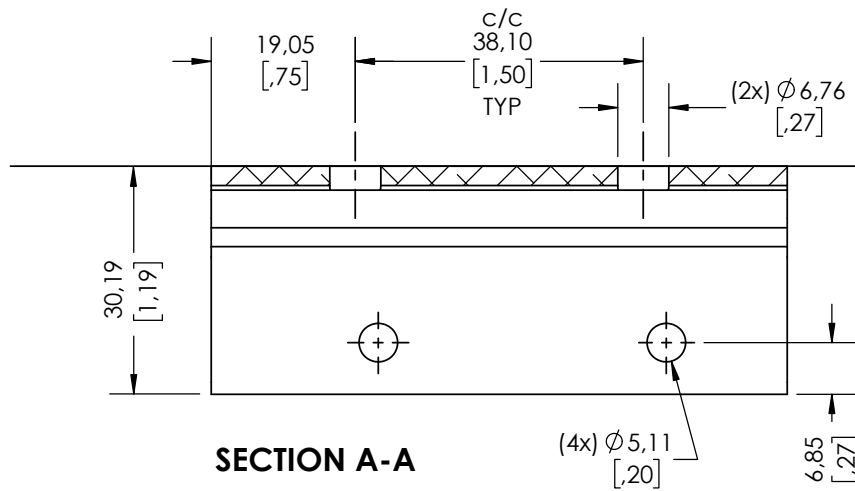

Anchoring hardware
(not included)

ANCHORING SIDE

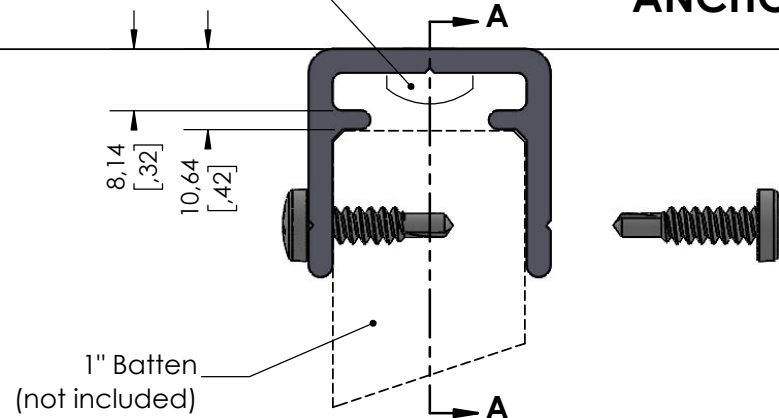

BATTEN SIDE

Recommended Span distance mounting for anchor screws (by others) and/or DIZAL Brackets is 8'-0" [2438mm] center to center*.
 *Calculated for 1" [25mm], 1.5" [38mm] and 2" [50mm] battens thickness from 2" [50mm] to 8" [203mm] width. For other dimensions, please contact us at info@dizal.com.
 NOTE: The first screw/bracket must be installed a maximum of 12" [305mm] from the batten end.
 IMPORTANT: Always check local building regulations before installing DIZAL battens.

THIS DRAWING IS THE PROPERTY OF DIZAL INC. ALL REPRODUCTIONS, IN FULL OR IN PART, MUST BE AUTHORIZED BY THE ABOVE MENTIONED. DIZAL RESERVES THE RIGHT TO MODIFY THE ELEMENTS ON THIS TECHNICAL DATA SHEET WITHOUT PRIOR NOTICE.

Pce/Part #	"CC" TYPE BRACKET - 1" BATTENS		
Description	Battens Bracket installation details		
Par/By	M.Savary	Date	22-11-14
Fin/Finish	RAL 7022 SMOOTH MATTE		
Unités/Units	mm [in]	Éch./Scale	1:1

CC BRACKET 1.5" BATTENS

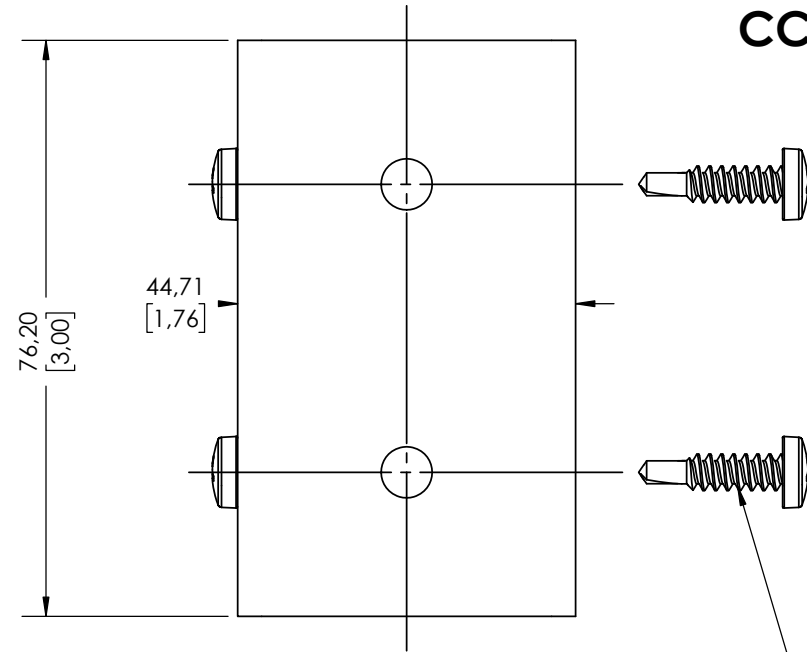
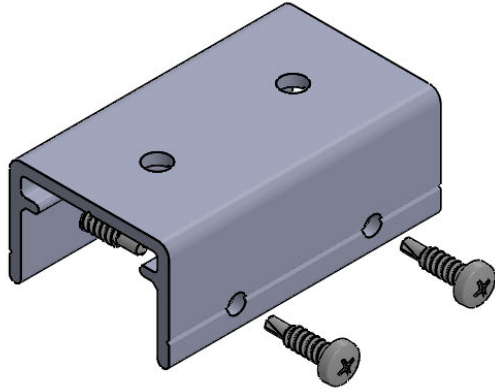

(4x) Painted 10-16 x 0.75"
self-drilling screws
per bracket (included)

Anchoring hardware
(not included)

ANCHORING SIDE

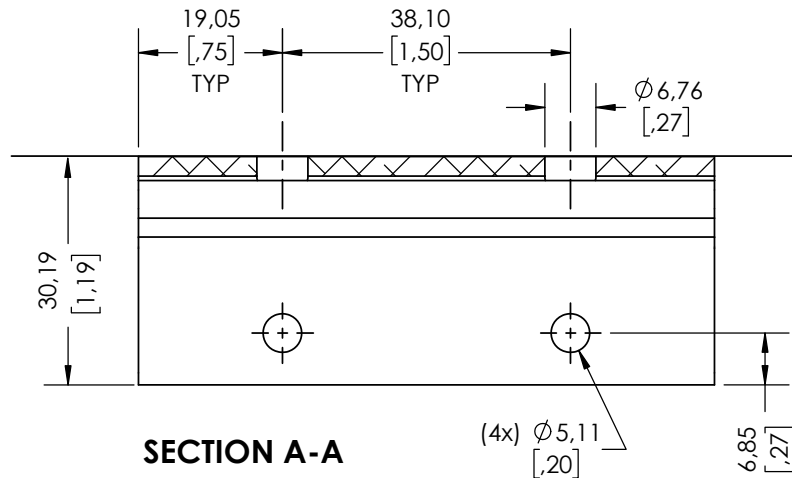

SECTION A-A

(4x) ϕ 5.11
[0.20]

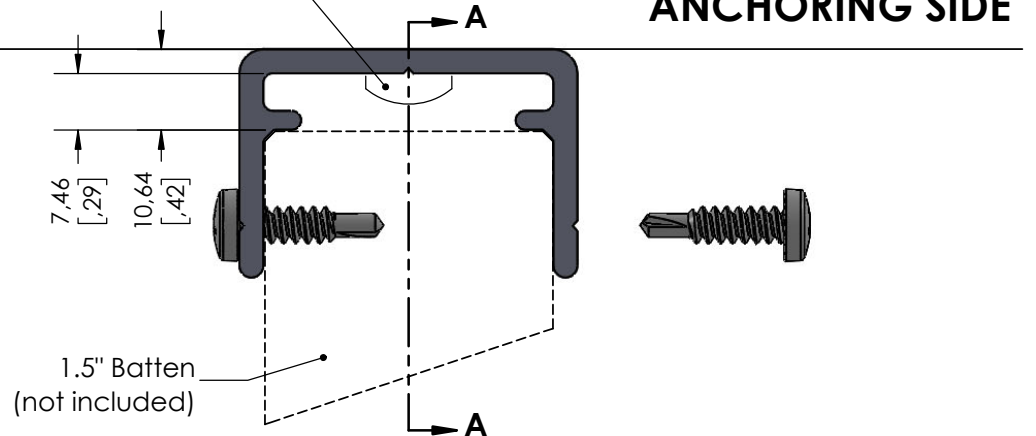

1.5" Batten
(not included)

BATTEN SIDE

Recommended Span distance mounting for anchor screws (by others) and/or DIZAL Brackets is 8'-0" [2438mm] center to center*.
*Calculated for 1" [25mm], 1.5" [38mm] and 2" [50mm] battens thickness from 2" [50mm] to 8" [203mm] width. For other dimensions, please contact us at info@dizal.com.
NOTE: The first screw/bracket must be installed a maximum of 12" [305mm] from the batten end.
IMPORTANT: Always check local building regulations before installing DIZAL battens.

THIS DRAWING IS THE PROPERTY OF DIZAL INC. ALL REPRODUCTIONS, IN FULL OR IN PART, MUST BE AUTHORIZED BY THE ABOVE MENTIONED. DIZAL RESERVES THE RIGHT TO MODIFY THE ELEMENTS ON THIS TECHNICAL DATA SHEET WITHOUT PRIOR NOTICE.

Pce/Part #	"CC" TYPE BRACKET - 1½" BATTENS		
Description	Battens Bracket installation details		
Par/By	M.Savary	Date	22-11-14
Fin/Finish	RAL 7022 SMOOTH MATTE		
Unités/Units	mm [in]	Éch./Scale	1:1

CC BRACKET 2" BATTENS

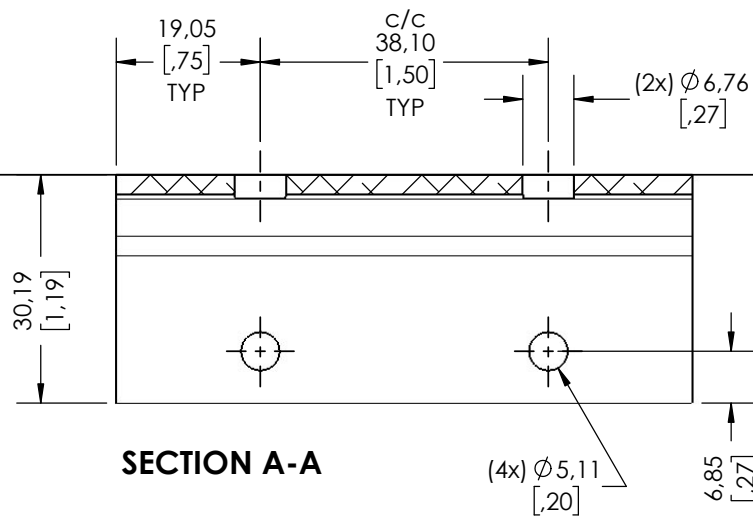
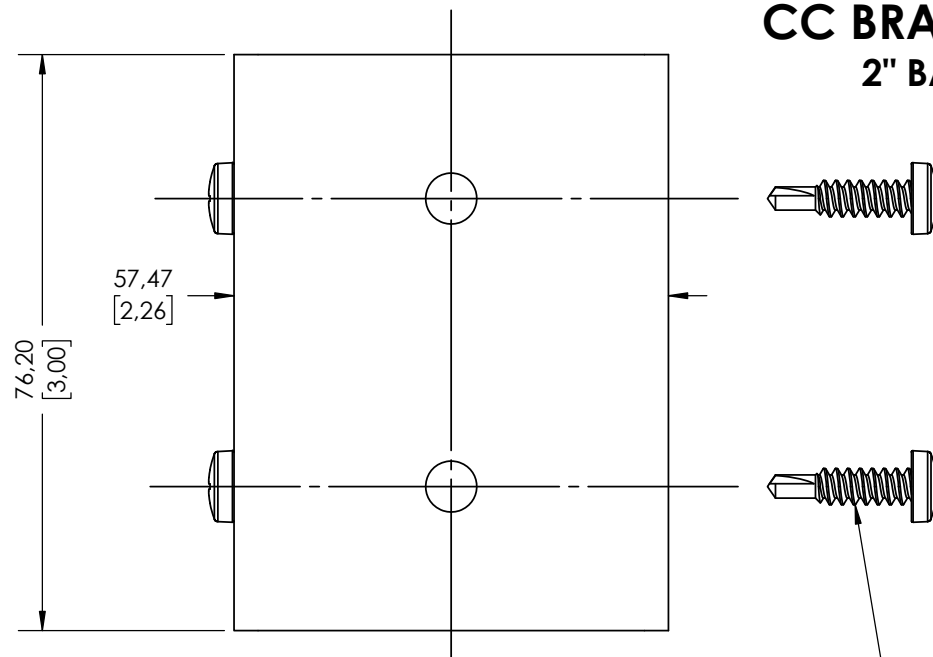
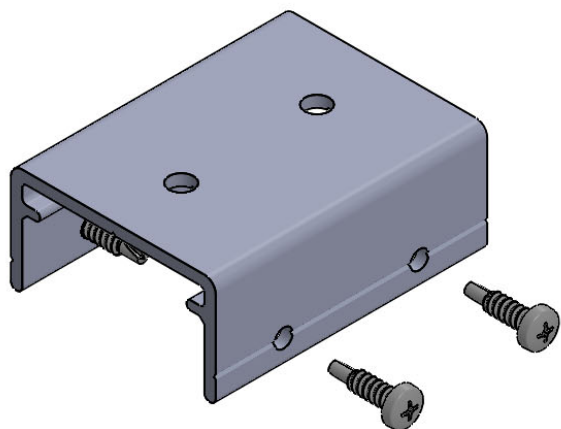

Anchoring hardware (not included)

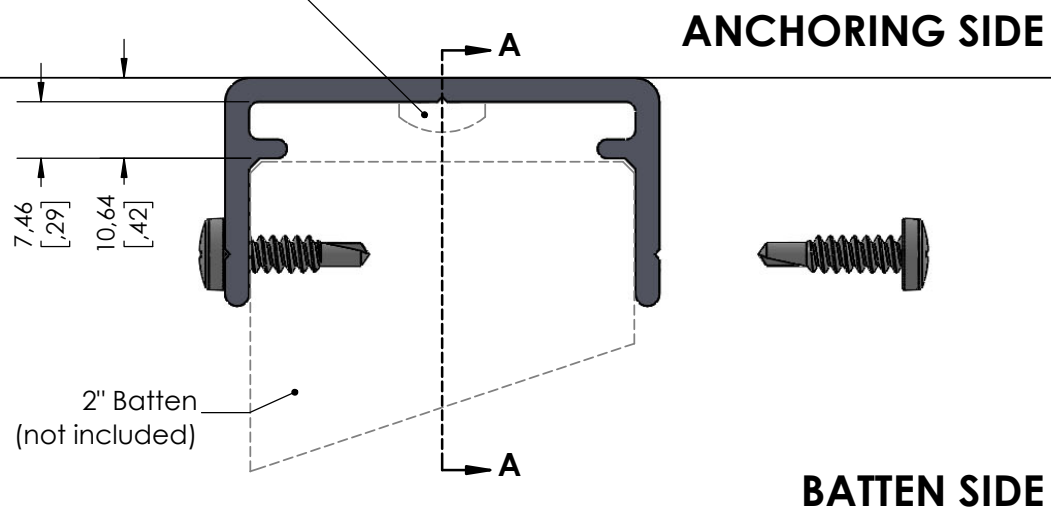

Recommended Span distance mounting for anchor screws (by others) and/or DIZAL Brackets is 8'-0" [2438mm] center to center*.
 *Calculated for 1" [25mm], 1.5" [38mm] and 2" [50mm] battens thickness from 2" [50mm] to 8" [203mm] width. For other dimensions, please contact us at info@dizal.com.
 NOTE: The first screw/bracket must be installed a maximum of 12" [305mm] from the batten end.
 IMPORTANT: Always check local building regulations before installing DIZAL battens.

THIS DRAWING IS THE PROPERTY OF DIZAL INC. ALL REPRODUCTIONS, IN FULL OR IN PART, MUST BE AUTHORIZED BY THE ABOVE MENTIONED. DIZAL RESERVES THE RIGHT TO MODIFY THE ELEMENTS ON THIS TECHNICAL DATA SHEET WITHOUT PRIOR NOTICE.

Pce/Part #	"CC" TYPE BRACKET - 2" BATTENS		
Description	Battens Bracket installation details		
Par/By	M.Savary	Date	22-11-14
Fin/Finish	RAL 7022 SMOOTH MATTE		
Unités/Units	mm [in]	Éch./Scale	1:1